

SYMPHONY SLIT LAMP

INSTRUCTIONS FOR USE

H Series

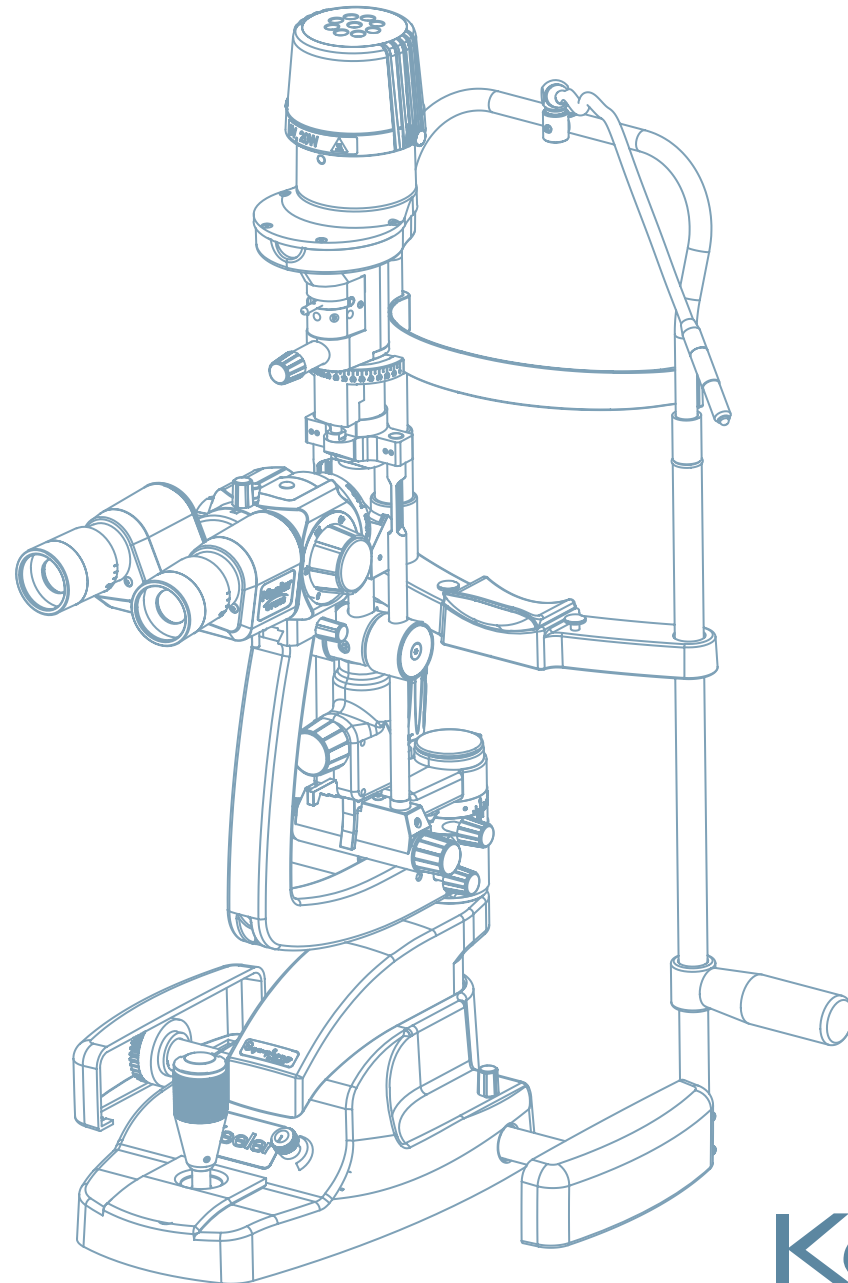

Symphony
by Keeler

Keeler

The information contained within this manual must not be reproduced in whole or part without the manufacturer's prior written approval. As part of our policy for continued product development we the manufacturer reserves the right to make changes to specifications and other information contained in this document without prior notice.

Copyright © Keeler Limited 2013. Published in the UK 2013.

CONTENTS

Please click on the contents to go straight to your chosen section or navigate by using the 'Next' and 'Back' buttons to the right. Clicking on 'Home' will bring you back to this page.

Introduction	2	Assembly	9
Symbols used in these Instructions for Use and the Slit Lamp packaging	3	Instructions for use	13
Indications for use	4	Description of filters, apertures and magnifications	15
Intended use/purpose of instrument		Routine maintenance	16
Brief description of the instrument		Warranty	17
Safety	5	Specifications and electrical ratings	18
Cleaning and disinfection instructions	7	Accessories and spares	21
Transport, storage and working conditions		Contact, packaging and disposal Information	23
Names of controls and components	8		

1 INTRODUCTION

Thank you for choosing this Keeler product.



Please read this manual carefully before using your Keeler Slit Lamp, this will ensure the safety of the patient and ensure you get the best performance from this precision optical device.

2 SYMBOLS USED IN THESE INSTRUCTIONS FOR USE AND THE SLIT LAMP PACKAGING



Manufacturer's name and address



Mandatory action sign



Follow Instructions for Use



Optical radiation hazard



Warning: Dangerous Voltage



Trip Hazard



Hot surface



General warning sign



Type B Applied Part



Non-ionizing radiation



Keep dry



Reference Number



Serial Number



Date of manufacture



The CE mark on this product indicates it has been tested to and conforms with the provisions noted within the 93/42/EEC Medical Device Directive



This way up



Material suitable for recycling



Fragile



The symbol on the Product or on it's Packaging and instructions indicates it was put on the market place after August 2005 and this product shall not be treated as Household Waste



Operating Instructions

3 INDICATIONS FOR USE

This Keeler Slit Lamp is an AC-powered Slit lamp biomicroscope and is intended for use in eye examination of the anterior eye segment, from the cornea epithelium to the posterior capsule. It is used to aid in the diagnosis of diseases or trauma which affects the structural properties of the anterior eye segment.

This device is intended to be used only by suitably trained and authorised healthcare professionals.



Federal Law restricts this device to sale by or on the order of a physician or practitioner.

4 INTENDED USE / PURPOSE OF INSTRUMENT

The Slit Lamp is an instrument consisting of a light source that can be focused to shine a thin sheet (slit) of light into the eye. It is used in conjunction with a biomicroscope. The lamp facilitates an examination of the anterior segment, or frontal structures and posterior segment, of the human eye, which includes the eyelid, sclera, conjunctiva, iris, natural crystalline lens, and cornea. The binocular Slit Lamp examination provides stereoscopic magnified view of the eye structures in detail, enabling anatomical diagnoses to be made for a variety of eye conditions.

5 BRIEF DESCRIPTION OF THE INSTRUMENT

This Keeler Slit Lamp can either be mounted onto a custom table top supplied by Keeler or can be mounted on a third parties table top (refraction unit) by suitably trained technicians.

The Keeler Slit Lamp consists of 5 assemblies; Illumination Tower; Observation System; XYZ Translation Base; Chinrest Assembly and a Table Top with Power Supply and Accessory Drawer.

The light intensity is controlled by a variable rheostat located on the XYZ Translation Base. There are a number of selectable filters allowing the user to control the characteristics of the examination light.

The Keeler Slit Lamp is designed and built in conformity with EC Directive 93/42/EEC and the ISO 9000 and ISO 13485 series of quality standards.

The 'CE' (European Community) mark attests that the Keeler Slit Lamp complies with the provisions of the EC Directive 93/42/EEC.

**Classification: CE Regulation 93/42 EEC: Class I
FDA: Class II
IEC/EN Standard 60601-1: H-series - Safety Class II
Application part: Type B
Operation mode: continuous operation**

Production processes, testing, start-up, maintenance, and repairs are conducted in strict conformity with the applicable laws and international reference standards.

6 SAFETY

6.1 PHOTO TOXICITY



Because prolonged intense light exposure can damage the retina, the use of the device for ocular examination should not be unnecessarily prolonged, and the brightness setting should not exceed what is needed to provide clear visualization of the target structures. This device should be used with filters that eliminate UV radiation (< 400 nm) and, whenever possible, filters that eliminate short-wavelength blue light (<420 nm).

The retinal exposure dose for a photochemical hazard is a product of the radiance and the exposure time. If the value of radiance were reduced in half, twice the time would be needed to reach the maximum exposure limit.

While no acute optical radiation hazards have been identified for slit lamps, it is recommended that the intensity of light directed into the patient's eye be limited to the minimum level which is necessary for diagnosis. Infants, aphakes and persons with diseased eyes will be at greater risk. The risk may also be increased if the person being examined has had any exposure with the same instrument or any other ophthalmic instrument using a visible light source during the previous 24 hours. This will apply particularly if the eye has been exposed to retinal photography.

It is well established that exposure of the eye to intense light sources for extended periods of time poses a risk of retinal **photic injury/ocular damage**.

Many ophthalmic instruments illuminate the eye with intense light. The light intensity on the Keeler Slit Lamp is continuously adjustable from maximum to zero. In addition there is an infra red filter incorporated in the illumination system to reduce IR light levels.



The light emitted from this instrument is potentially hazardous. The longer the duration of exposure, the greater the risk of ocular damage. Exposure to light from this instrument when operated at maximum intensity will exceed the safety guideline after a period of 13 minutes when using ancillary 90D lens.

Keeler Ltd shall on request, provide the user with a graph showing the relative spectral output of the instrument

6.2 WARNINGS AND CAUTIONS

Observe the following prescriptions in order to ensure safe operation of the instrument

WARNINGS



- Never use the instrument if visibly damaged and periodically inspect it for signs of damage or misuse.
- Check your Keeler product for signs of transport / storage damage prior to use.
- Do not use in the presence of flammable gases / liquids, or in an oxygen rich environment.
- US Federal Law restricts this device to sale by or on the order of a physician or practitioner.
- This device is intended to be used only by suitably trained and authorised healthcare professionals.
- This product should not be immersed in fluid.
- Repairs and modifications to the instrument must be made only by the specialized technicians of the manufacturer's Technical Service Centre or by personnel trained and authorised by the manufacturer. The manufacturer declines any and all responsibility for loss and/or damages resulting from unauthorised repairs; furthermore, any such actions will invalidate the warranty.



- Route power cords safely to eliminate risk of tripping or damage to user.



- Before any cleaning of the instrument or the base unit ensure the power lead is disconnected.



- Bulbs can reach high temperatures in use – allow to cool before handling.



- Do not exceed maximum recommended exposure time.
- Should the instrument suffer shocks (for example, should it accidentally fall), and the optical system or the illumination system are damaged it may be necessary to return the instrument to the manufacturer for repair.
- Care should be taken when handling halogen bulbs. Halogen bulbs can shatter if scratched or damaged.
- After removal of the bulb, do not touch the Slit Lamp bulb electrical contacts and patient simultaneously.
- The owner of the instrument is responsible for training personnel in its correct use.
- Ensure the instrument or instrument table is placed on a level and stable surface.
- Use only genuine Keeler approved parts and accessories or device safety and performance may be compromised.
- Shut down after every use. In case the dust cover is used: risk of overheating.
- For indoor use only (protect from moisture).
- Electrical equipment can be affected by electromagnetic interference. If this occurs whilst using this equipment, switch the unit off and reposition.
- Do not touch accessible connectors and the patient simultaneously.

7 CLEANING AND DISINFECTION INSTRUCTIONS



Before any cleaning of the instrument or the base unit, ensure the power lead is disconnected.

Only manual non-immersion cleaning as described should be used for this instrument. Do not autoclave or immerse in cleaning fluids. Always disconnect power supply from source before cleaning.

- a Wipe the external surface with a clean absorbent, non-shedding cloth dampened with a water / detergent solution (2% detergent by volume) or water / isopropyl alcohol solution (70% IPA by volume). Avoid optical surfaces.
- b Ensure that excess solution does not enter the instrument. Use caution to ensure cloth is not saturated with solution.
- c Surfaces must be carefully hand-dried using a clean non-shedding cloth.
- d Safely dispose of used cleaning materials.

8 TRANSPORT, STORAGE AND WORKING CONDITIONS

The following ambient condition limits are recommended for the Keeler Slit Lamp, for transport and storage it is recommended that the Slit Lamp is kept in its original manufacturers packaging.

WORKING ENVIRONMENT

+10°C to +35°C

30% to 75% relative humidity

TRANSPORT AND STORAGE CONDITIONS

Transport: -40°C to +70°C

Storage: -10°C to +55°C



Before use, the Slit Lamp should be allowed to adjust to the ambient room temperature for several hours. This is especially important when the unit has been stored or transported in a cold environment; this can cause severe condensation to develop on the optical elements.

9 NAMES OF CONTROLS AND COMPONENTS

HEADREST ASSEMBLY

1. Fixation light cable
2. Main lamp cable (4 pin socket)
3. Forehead rest band
4. Patient's eye height marker
5. Fixation light
6. Chinrest
7. Chinrest height adjuster
8. Patient grab handles
9. Power lead, chinrest to lamp housing

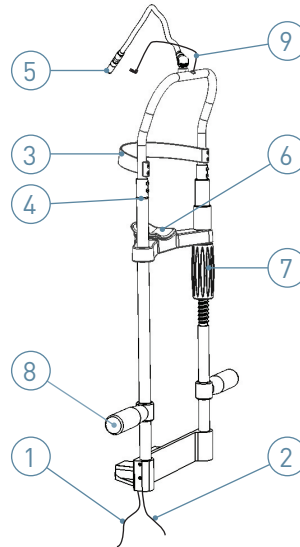

KEELER SLIT LAMP, H SERIES

10. Lamp cover
11. Lamp cover release screws
12. Lever for grey (ND), blue, diffuser and red free filters
13. Slit length, slit rotation and aperture control
14. Scale for slit rotation
15. Illumination mirror
16. Slit offset centring knob
17. Inclination latch 5° to 20°
18. Slit width controls
19. Test bar & tonometer plate mounting hole and cover
20. Illumination arm locking knob
21. Microscope arm locking knob
22. Eyepiece assembly securing knob

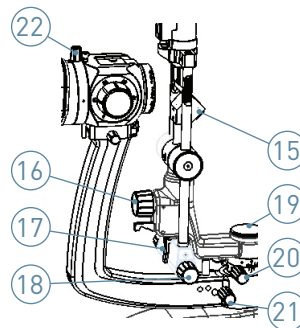
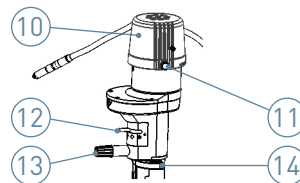

23. Joystick base locking knob
24. Joystick control (X Y Z movement)
25. Illumination control rheostat

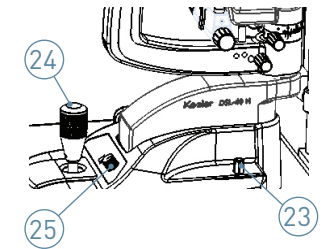

26. Axle
27. Runner covers

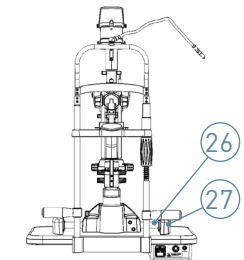

28. R type tonometer mounting hole
29. Yellow filter knob (up = out)
30. Lock for securing magnification body
31. Magnification change drum
32. Eyepieces – adjustable for PD and dioptre correction
33. Breath shield securing knob

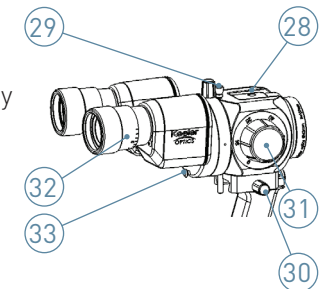

34. Main power switch
35. Power supply unit
36. Glide plate

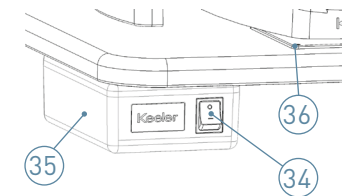

10 ASSEMBLY

Your Keeler Slit Lamp has been designed to fit on to an electric insulated medical table base or on to an electric insulated and fire resistant medical table top, e.g. a Refraction Stand or Combi Unit.

Take care when unpacking your Slit Lamp that you do not accidentally damage or discard any of the contents.



Leave the Slit Lamp in the packing for several hours after delivery before unpacking to reduce the risk of condensation forming.

Keeler Slit Lamps can be fitted to most Refraction Stands / Combi units. Keeler recommends that this be carried out by suitably trained technicians to ensure performance and safety are not compromised.



The Refraction Stand, Combi Unit or table leg must be 60601-1 3rd edition compliant

If you are fitting or have fitted your Slit Lamp to a medical or Keeler table leg/base ensure it is situated on a firm and level floor.

If the table leg/base has castors ensure the following before moving it to another location:

- The table is at its lowest position
- The power cord is removed
- The slit lamp arm and base locking knobs are tightened
- The Runner covers are securely located
- The system is moved by grasping it at its lowest practical point.

10.1 TABLE TOP AND BASE ASSEMBLY PROCEDURE

- 1 Attach the Slit Lamp table top to your table leg using the M6 x 20mm CAP head fasteners and washers. Note that the power supply and accessory drawer should face the operator.



The security of the fitment of the table top to the table leg is critical for patient and Slit Lamp safety

- 2 Using the wrench provided, fit the Chinrest to the tabletop using the hex bolts and washers. The Chinrest locates on the underside of the tabletop. Take care not to over tighten the hex bolts.
- 3 Attach the Patient Grab Handles (8) to the Chinrest.
- 4 Place the Slit Lamp base on the Runners. Ensure that the wheels are in line with each other. Check that the guide wheels are tight.
- 5 Fit the Runner covers to the Runners by gently sliding them inwards, towards each other.

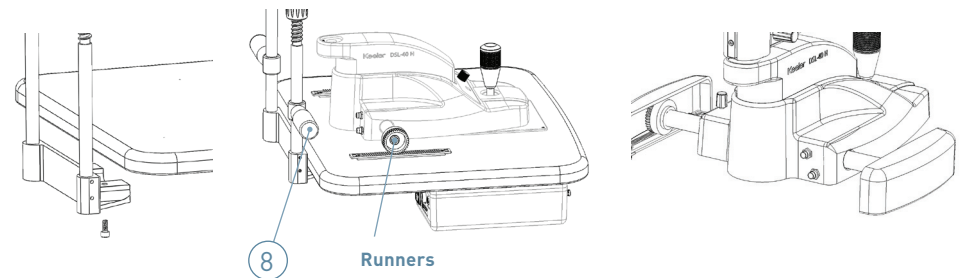

10.2 ILLUMINATION TOWER ASSEMBLY PROCEDURE

- 1 Remove the hex bolt (a) from the base of the Illumination tower, and then place the illumination tower on the Slit Lamp base with the base notch (b) and pin(c) aligned. Attach the tower to the base using the hex bolt removed earlier and tighten using the wrench provided.

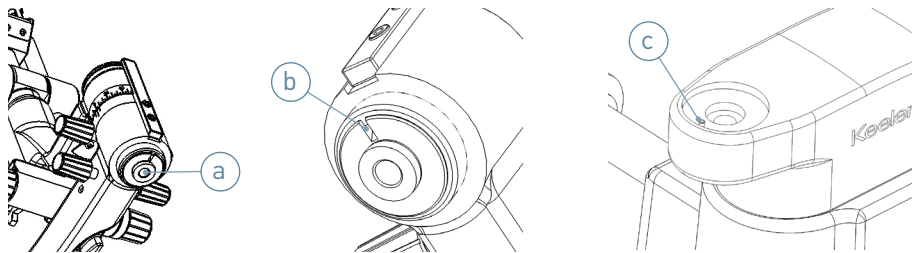

- 2 Carefully fit the microscope body to the arm – ensuring it is pushed to the stop. Tighten using the securing knob on the side.

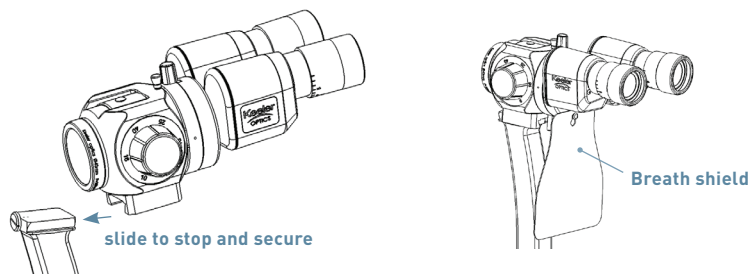

- 3 Attach the breath shield to the pin on the rear of the magnification assembly.

10.3 CABLE ATTACHMENT PROCEDURE

- 1 Connect the main lamp cable from the Chinrest to the illumination tower. Do not twist the lead on the tower illumination system.
- 2 Connect the power cables
 - a) Chinrest fixation light cable to power supply unit
 - b) (3 pin) cable from power supply unit to slit lamp base assembly
 - c) (4 pin) main lamp cable from bottom of the chinrest to the slit lamp base assembly.
 - d) Ensure cables are routed to avoid to allow free movement of the XYZ base and to be clear of the patients.

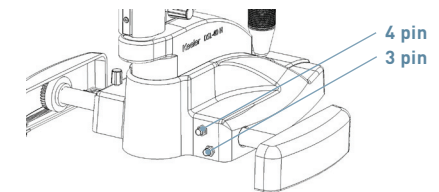
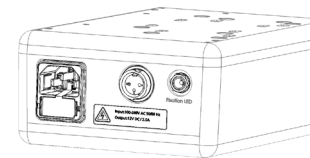
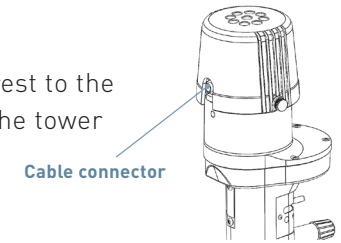

If your Slit Lamp was not supplied with a transformer (Part #3020-P-5040, make sure that the power connection is compatible with the specifications in this manual and is connected by a qualified technician to an available and suitable power supply, see section 15.5 Power Supply

- 3 Connect the mains power to the Slit Lamp transformer using the power lead provided.

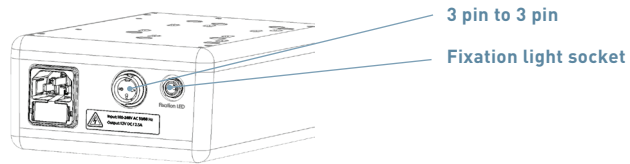

Only a hospital grade 3-conductor electrical power supply cable must be used. For USA and Canada: Detachable power supply cord set, UL listed, type SJE, SJT or SJO, 3-conductor, not smaller than 18 AWG. Plug, cable and ground lead connection of the socket have to be in perfect condition

10.4 FITTING APPLANATION TONOMETERS, T TYPE AND R TYPES

KEELER APPLANATION TONOMETER (T-TYPE)

- Position the guide plate in the tonometer/test bar support hole on the slit lamp.
- Lift Tonometer out of the packaging and assemble it by inserting the pin on its base into one of the two possible openings (for right or left eye) on the horizontal guide plate above the slit lamp axis. These positions are related to the microscope optics and observation can be made either through the right or the left eye-piece.
- The tonometer will slip easily onto the support plate; stability is assured by the locking pins.
- To obtain an image as clear and as free of reflexes as possible, the angle between the illumination and the microscope should be about 60° and the slit diaphragm should be fully opened.
- When not in use the Tonometer should be removed from the Slit Lamp and placed securely back in the packaging or a suitable location.

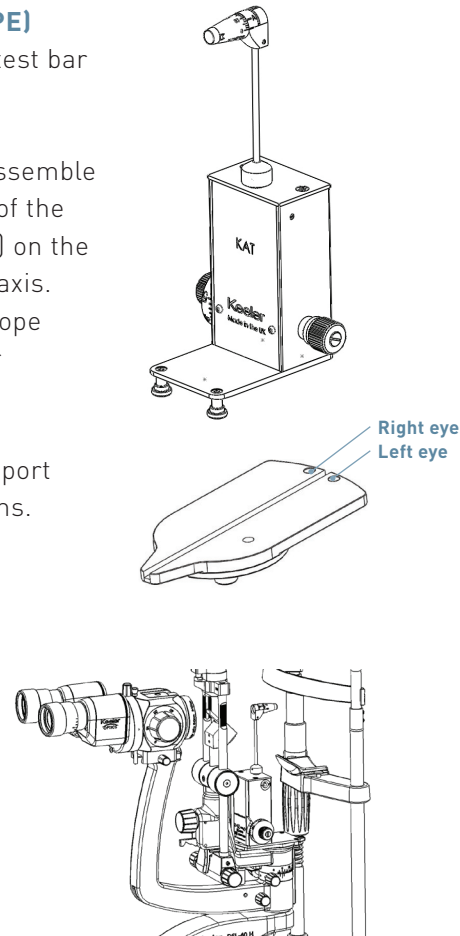

APPLANATION TONOMETER 'KEELER FIXED' (R-TYPE)

This instrument is for those who wish the tonometer to remain permanently on the slit lamp.

- Mount the plate for the tonometer onto the microscope body using the securing screw.
- Then mount the tonometer mount onto the mounting post.
- Swing the Tonometer forward in front of the microscope for examination. A notch position ensures exact centring of the prism with the left objective.
- To obtain an image as clear and as free of reflexes as possible, the angle between the illumination and the microscope should be about 60° and the slit diaphragm should be fully opened.
- When not in use the instrument is swung around and secured in a notch position to the right of the microscope.

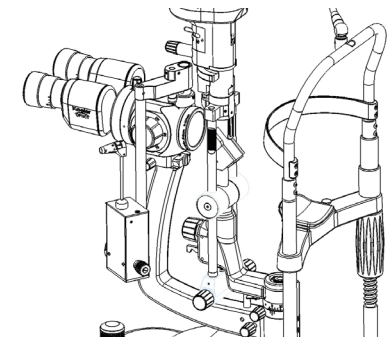
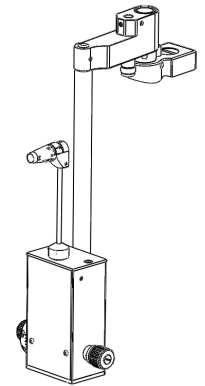

11 INSTRUCTIONS FOR USE

11.1 SETTING THE BINOCULARS



It is vital that the binoculars are optimised for the user's optical correction in order to obtain focused binocular images.

- 1 Remove the Test Bar locating hole cover plate (19) and place the test bar focus in the test bar location hole at the base of the microscope arm. To access the location hole first remove the cover. The test bar should be set with the flat projection face towards the Slit Lamp Microscope. The illumination and the microscope should be in the zero degrees position.
- 2 Turn on the Slit Lamp, and set the slit to full width (18), set the magnification to x16 (31).

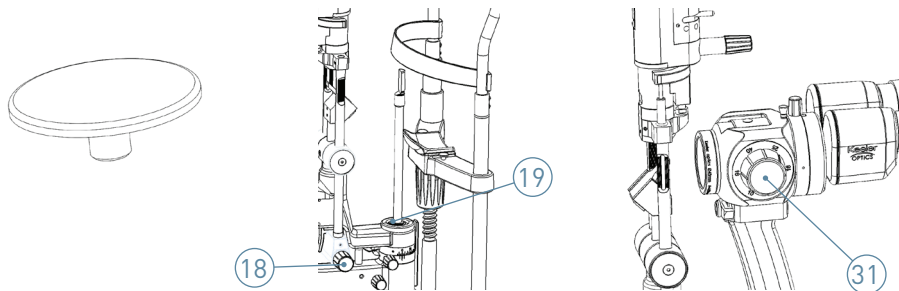

- 3 Adjust the eyepieces pupillary distance by holding both eyepiece bodies and rotating them inwards or outwards until they are correct for your PD.
- 4 Turn both eyepieces (32) to maximum plus (+) correction.

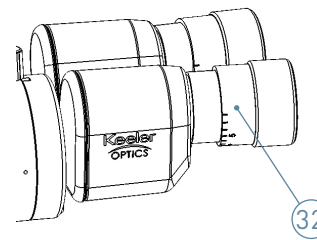

- 5 Close one eye, and with the other eye look through the microscope slowly turning the open eye eyepiece towards the minus (-) position until the image of the test bar is in focus. Stop.
- 6 Repeat the above process for the other eyepiece.
- 7 Make a note of the positions of the eyepieces so that you can set them quickly if the Slit Lamp has been used by another clinician.
- 8 Note – younger examiners are recommended to compensate for their ability to accommodate by further adjusting the eyepieces by minus one (-1) or minus two (-2) dioptres.

11.2 PREPARING THE PATIENT AND USING THE SLIT LAMP



Parts of the slit lamp coming in to contact with the patient should be cleaned in accordance with these instructions prior to the examination. Keeler recommends the use of disposable hygienic chinrest tissues on the Chinrest before the patients place their chin on it.



Never use the instrument if visibly damaged and periodically inspect it for signs of damage or misuse.

- 1 The patient should be as comfortable as possible and with the patient in the chinrest adjust the chinrest height (7) so that the patient's eyes are level with the height marking (4) on the chinrest support.
- 2 Focus the eyepieces using the test bar as described earlier, and if you have not already done so set them to your interpupillary distance by holding both eyepiece bodies and rotating them inwards or outwards until they are correct for your PD.
- 3 Switch on the illumination, making sure the rheostat (25) is set to a low level to minimise the patient's exposure to light hazard.
- 4 Rotate the joystick (24) until the light beam is at eye level.
- 5 Holding the joystick vertical, move the slit Lamp base towards the patient until the slit beam appears focused on the patient's cornea.

- 6 Adjust slit width (18), magnification (31), slit rotation (13) & slit angle etc. as required to perform the examination.
- 7 Loosening slit offset centring knob (16) to allow the slit image to be moved off centre for scleral illumination. Tightening the knob will re-centre the slit image in the centre of the visual field of the microscope.
- 8 The slit image is made vertical, or given a preset angle by means of the illumination latch (17) (notches at 5°, 10° and 15° & 20°).
- 9 When using the blue filter (12) the user may wish to insert the yellow barrier filter (29). The yellow barrier filter is out when the knob is up, in when it is down.
- 10 When the examination is complete, set the rheostat to a low level and switch off the Slit Lamp.

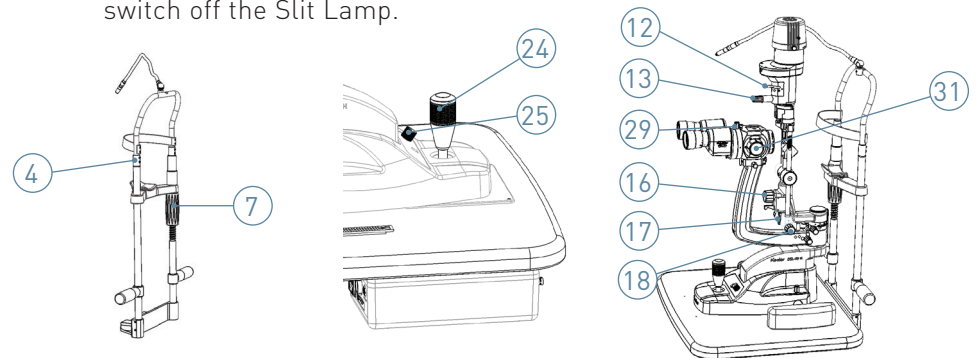

Shut down after every use. In case the dust cover is used: risk of overheating.

12 DESCRIPTION OF FILTERS, APERTURES AND MAGNIFICATIONS

STEREO MICROSCOPE

Eyepieces	12.5x
Dioptric adjustment	+/- 8D
PD range	49mm – 77mm
Convergent angle of optical axis	13°

5 step magnification change

Magnification	Field of view
6x	34mm
10x	22mm
16x	14mm
25x	8.5mm
40x	5.5mm

FILTERS

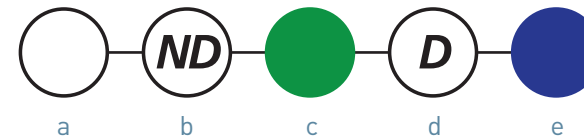

An Infra Red (IR) cut filter is permanently fitted for safety reasons

- a Clear
- b Neutral Density
- c Red Free
- d Diffuser
- e Blue

APERTURES

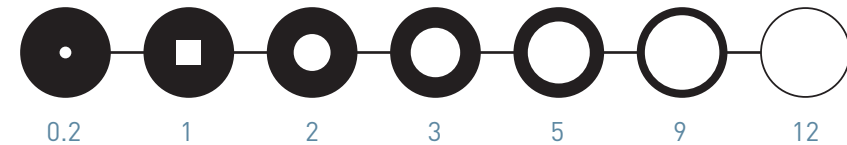

Aperture diameters (mm)

TOWER ILLUMINATION

Tower has the facility to tilt towards the user and positively locates at each step. 0°, 5°, 10°, 15° and 20°.

13 ROUTINE MAINTENANCE



The maintenance outlined below should only be carried out once the main power cable has been disconnected. If you have any problems that are not covered by the procedures described below, contact Keeler Ltd or your local supplier.

13.1 BULB REPLACEMENT (6V 20W AND 12V 30W SYSTEMS ONLY)



First disconnect the mains power from your Slit Lamp. Allow the failed lamp and housing to cool down before removing it.

When replacing the bulb do not touch the bulb contacts and the patient simultaneously.

- Disconnect the power cord to the lamp housing and remove the lamp cover on tower illumination systems by loosening the two screws on the lamp housing.
- Carefully disconnect the power leads from the lamp pins by pulling off the connecting plug.
- Loosen and remove the screw holding the lamp retaining clip.
- Remove the burnt out lamp. Be careful it may still be hot!

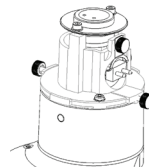
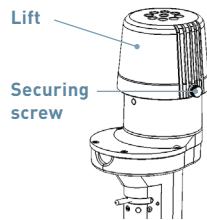

- Replace it with a new 6V 20W halogen lamp, take care to avoid handling the lamp glass
- Replace the lamp retaining clip
- Replace the power connections to the lamp
- Replace the lamp housing or lamp cover.

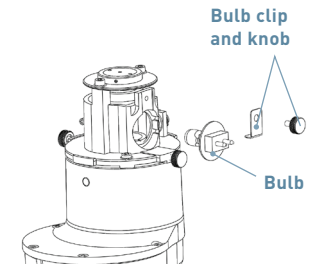

13.1.1 LED SYSTEMS

LED's typically have a life exceeding 10,000 hours of continuous use and therefore can be considered as a non-consumable item that will not require changing by a user.

Whilst this is a significant life expectancy we suggest that the Slit Lamp is always switched off between examinations to conserve energy and LED life.

In the unlikely event of an LED failure please contact Keeler or your local distributor for guidance on the replacement procedure.

13.2 REGULARLY INSPECT THE DEVICE FOR DAMAGE OR DIRT

Routinely clean as per section 7 Cleaning Instructions.

13.3 CLEANING AND CHANGING THE MIRROR

The mirror is front surfaced to avoid ghosting of the projected light and therefore is very delicate and will need to be replaced when the surface deteriorates.

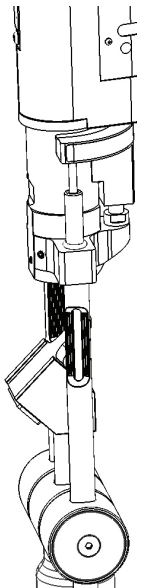

The mirror should be cleaned only with a soft clean lens cloth.

The mirror is interference fit in its holder and can be removed by grasping it firmly and pulling it out of its holder. Slide in the replacement mirror taking care to avoid touching the reflective surface.

Care must be taken to keep the objective and the eyepiece lenses clean – use only soft clean lens cloths to clean optical surfaces.

13.4 ELECTRICAL CONNECTIONS

Routinely check all electrical connections, cables and connectors. To access the bulb connections see earlier in this section for guidance.

13.5 OPTICS

The optics should be blown clean of any loose dirt or debris with a suitable dust brush then cleaned with a soft dry lens cloth, washed linen or other non abrasive lens cleaning material.

The condenser lens beneath the illumination lamp will require cleaning; to access this, remove the lamp as detailed earlier, clean the condenser lens and then replace the lamp.

13.6 AXLE AND MECHANICAL PARTS

If the Slit Lamp becomes hard to move on the glide plate, the plate should be cleaned with a lightly oiled cloth or silicon polish. The axle should be cleaned only with dry lint free cloths.

14 WARRANTY = 3 YEARS

The Keeler Symphony H-Series Slit Lamps are guaranteed for three years (3) against faulty workmanship materials or factory assembly. Warranty is on a Return To Base (RTB) basis at the cost of the customer and may be void if the Slit Lamp has not been regularly serviced.

The manufacturers warranty and terms and conditions are detailed on the Keeler UK website http://www.keeler.co.uk/terms_and_conditions.htm

The mirror, main illumination lamp and general 'wear and tear' are excluded from our standard warranty.



The manufacturer declines any and all responsibility and warranty coverage should the instrument be tampered with in any manner or should routine maintenance be omitted or performed in manners not in accordance with these manufacturer's instructions.

There are no user serviceable parts in this instrument. Any servicing or repairs should only be carried out by Keeler Ltd. or by suitably trained and authorised distributors. Service manuals will be available to authorised Keeler service centres and Keeler trained service personnel.

15 SPECIFICATIONS AND ELECTRICAL RATINGS

The Keeler Slit Lamp is a medical electrical instrument. The instrument requires special care concerning electromagnetic compatibility (EMC). This Section describes its suitability in terms of electromagnetic compatibility of this instrument. When installing or using this instrument, please read carefully and observe what is described here.

Portable or mobile-type radio frequency communication units may have an adverse effect on this instrument, resulting in malfunctioning.

15.1 ELECTROMAGNETIC EMISSIONS

Guidance and manufacturer's declaration – electromagnetic emissions

The Keeler Slit Lamp is intended for use in the electromagnetic environment specified below. The customer or user should assure that it is used in such an environment.

Emissions test	Compliance	Electromagnetic environment - guidance
RF emissions CISPR 11	Group 1	The Keeler Slit Lamp uses RF energy only for its internal function. Therefore, its RF emissions are very low and are not likely to cause any interference in nearby electronic equipment.
RF emissions CISPR 11	Class B	The Keeler Slit lamp is suitable for use in all establishments, including domestic establishments and those directly connected to the public low-voltage power supply network that supplies buildings used for domestic purposes.
Harmonic emissions IEC 61000-3-2	Class A	
Voltage fluctuations / flicker emissions IEC 61000-3-3	Complies	

15.2 INTERFERENCE IMMUNITY

Guidance and manufacturer's declaration – electromagnetic immunity

The Keeler Slit Lamp is intended for use in the electromagnetic environment specified below. The customer or user should assure that it is used in such an environment.

Immunity test	IEC 60601 Test level	Compliance level	Electromagnetic environment - guidance
Electrostatic discharge (ESD). IEC 6100-4-2	± 6 kV contact ± 8 kV air	± 6 kV contact ± 8 kV air	The Keeler Slit Lamp uses RF energy only for its internal function. Therefore, its RF emissions are very low and are not likely to cause any interference in nearby electronic equipment.
Electrical fast transient/burst. IEC 61000-4-4	± 2 kV for power supply lines ± 1 kV for power supply lines	± 2 kV for power supply lines ± 1 kV for power supply lines	Mains power quality should be that of a typical commercial or hospital environment.
Surge. IEC 61000-4-5	± 1 kV line(s) to line(s) ± 2 kV line(s) for input/output line(s)	± 1 kV line(s) to line(s) ± 2 kV line(s) for input/output line(s)	Mains power quality should be that of a typical commercial or hospital environment.
Voltage dips, short interruptions and voltage variations on power supply input lines. IEC 61000-4-11	<5% U_T (> 95% dip in U_T) 40% U_T (60% dip in U_T) for 5 cycles 70% U_T (30% dip in U_T) for 25 cycles <5% U_T (>95% dip in U_T) for 5 s	<5% U_T (> 95% dip in U_T) 40% U_T (60% dip in U_T) for 5 cycles 70% U_T (30% dip in U_T) for 25 cycles <5% U_T (>95% dip in U_T) for 5 s	Mains power quality should be that of a typical commercial or hospital environment. If the user of the Keeler Slit Lamp requires continued operation during power mains interruptions, it is recommended that the instrument be powered from an uninterruptible power supply.
Power frequency (50/60 Hz) magnetic field. IEC 61000-4-8	3 A/m	3 A/m	Power frequency magnetic fields should be at a level characteristic of a typical location in a typical commercial or hospital environment.

Note: U_T is the a. c. mains voltage prior to application of the test level.

15.3 ELECTROMAGNETIC IMMUNITY

Guidance and manufacturer's declaration – electromagnetic immunity

The Keeler Slit Lamp is intended for use in the electromagnetic environment specified below. The customer or user should assure that it is used in such an environment.

Immunity test	IEC 60601 Test level	Compliance level	Electromagnetic environment - guidance
			Portable and mobile RF communications equipment should be used no closer to any part of the Keeler Slit Lamp, including cables, than the recommended separation distances calculated from the equation applicable to the frequency of the transmitter.
			Recommended separation distance
Conducted RF IEC 61000-4-6	3 Vrms	3 V	$d = 1.2 \sqrt{p}$
Radiated RF IEC 61000-4-3	3 V/m 80MHz to 2.5GHz	3 V/m	$d = 1.2 \sqrt{p}$ 80MHz to 800 MHz $d = 2.3 \sqrt{p}$ 800MHz to 2.5GHz
			Where p is the maximum output power rating of the transmitter in watts (W) according to the transmitter manufacturer and d is the recommended separation distance in metres(m). Field strengths from fixed RF transmitters, as determined by an electromagnetic site survey ¹ , should be less than the compliance level in each frequency range. ²
			 Interference may occur in the vicinity of equipment marked with the this symbol.

Note: At 80MHz and 800MHz, the higher frequency range applies. These guide lines may not apply in all situations. Electromagnetic propagation is affected by absorption and reflection from structures, objects and people.

¹ Field strengths from fixed transmitters, such as base stations (cellular / cordless) telephones and land mobile radios, amateur radio, AM and FM radio broadcast and TV broadcast cannot be predicted theoretically with accuracy. To assess the electromagnetic environment due to fixed RF transmitters, an electromagnetic site survey should be considered. If the measured field strength in the location in which the Keeler Slit Lamp is used exceeds the applicable RF compliance level above, the Keeler Slit Lamp should be observed to verify normal operation. If abnormal performance is observed, additional measures may be necessary, such as re-orientating or relocating the Keeler Slit Lamp.

² Over the frequency range 150kHz to 80 MHz, field strengths should be less than 3 V/m.

15.4 RECOMMENDED SAFE DISTANCES

Recommended separation distances between and mobile RF communications equipment and the Keeler Slit Lamp

The Keeler Slit Lamp is intended for the use in an electromagnetic environment in which radiated RF disturbances are controlled. The customer or the user of the Keeler Slit Lamp can help prevent electromagnetic interference by maintaining a minimum distance between and mobile RF communications equipment (transmitters) and the Keeler Slit Lamp as recommended below, according to the maximum output power of the communications equipment.

Rated maximum output power of transmitter (W)	Separation distance according to frequency of transmitter (m)		
	50 kHz to 80MHz $d = 1.2 \sqrt{p}$	80MHz to 800MHz $d = 1.2 \sqrt{p}$	800MHz to 2.5GHz $d = 2.3 \sqrt{p}$
0.01	0.12	0.12	0.23
0.01	0.37	0.37	0.74
1	1.2	1.2	2.3
10	3.7	3.7	7.4
100	12	12	23

For transmitters rated at a maximum output power not listed above, the recommended separation distance d in metres (m) can be determined using the equation applicable to the frequency of the transmitter, where p is the maximum output power rating of the transmitter in watts (W) according to the transmitter manufacturer.

Note: At 80MHz and 800MHz, the separation distance for the higher frequency applies. These guidelines may not apply in all situations. Electromagnetic propagation is affected by absorption and reflection from structures, objects and people.

15.5 TECHNICAL SPECIFICATIONS

OPTICAL SYSTEM

Type	Galilean converging binoculars @ 8°
Magnification	Rotating drum change x6, x10, x16, x25 & x40
Eyepiece	x12.5
Field of view	34, 22, 14, 8.5 and 5.5 mm
Interpupillary distance	49.0 to 77mm
Objective lens focal distance	107mm
Objective lens convergence angle	13°

SLIT PROJECTION SYSTEM & BASE

Slit Width	0-12mm continuously variable
Slit Length	12mm (1mm – 12mm continuously variable)
Aperture diameters	0.2, 1mm square, 2, 3, 5, 9 and 12mm
Filters	Clear; red free; neutral density; diffuser; blue; IR heat absorbing filter permanently installed
Slit angle	+/- 90° continuous
Slit rotation	+/- 180° with reference scale
Slit vertical Tilt	0°, 5°, 10°, 15° & 20°
Base travel	25mm Z-axis, 107mm X-axis, 110mm Y axis
Horizontal fine adjustment	12mm
Table top dimensions	405 x 500mm
Fixation lamp	LED
Light source	6V 20W Halogen lamp / LED

WEIGHT, PACKED (APPROX.)

Slit Lamp with chinrest	20.0Kg, 75 x 54 x 45cm W x D x H
Table top with PSU & Acc drawer	5.2Kg, 51 x 42 x 15cm W x D x H

SYSTEM COMPONENTS

	Part number
Slit Lamp Symphony 40H, Standard Set complete with Table Top	3020-P-2000
Slit Lamp	3020-P-5032
PSU	3020-P-5040
Slit Lamp Symphony 40H, Refraction Unit Set	3020-P-2003
Slit Lamp	3020-P-5032
Power Supply and Socket Kit	3020-P-7017
Slit Lamp Symphony 40H LED, Standard Set complete with Table Top	3020-P-2007
LED Slit Lamp	3020-P-5056
PSU	3020-P-5040
Slit Lamp Symphony 40H LED, Refraction Unit set	3020-P-2006
LED Slit Lamp	3020-P-5056
Power Supply and Socket Kit	3020-P-7017
The power supply forms part of the ME Equipment	

PROTECTION AGAINST INGRESS IPx0

CLASS II ME EQUIPMENT

Insulation between mains parts and the functional earth provide at least two means of protection.

POWER SUPPLY

	Part number
Power supply unit	Switch mode, (110V – 240V input) +/- 10% multi plug compliant to EN60601-1 EN 61000-6-2, EN 61000-6-3
Power supply output	12V DC: 2.5 amps must be IEC/EN 60601 compliant
Complies with	Electrical Safety (Medical) BS EN 60601-1 Electromagnetic compatibility EN 60601-1-2 Ophthalmic instruments - Fundamental requirements and test methods ISO 15004-1 Ophthalmic instruments - Optical radiation hazard ISO 15004-2

ENVIRONMENTAL

	Temperature	Humidity	Pressure
Use	+10°C to +35°C	30% to 90%	800 hpa to 1060 hpa
Storage	-10°C to +55°C	10% to 95%	700 hpa to 1060 hpa
Transport	-40°C to +70°C	10% to 95%	500 hpa to 1060 hpa

16 ACCESSORIES AND SPARES

SUPPLIED WITH YOUR SLIT LAMP

Part name	Part number
Test bar	EP39-80243
	
Bulb	1030-P-7160
	
Small projection mirror	EP39-80250
	
Long projection mirror (standard)	EP39-80052
	
Dust cover	EP39-80273

Part name	Part number
Chinrest papers	3104-L-8200
Chinrest assembly	3020-P-5036
Power supply to Slit Lamp base cable (Table top variant only)	3020-P-7011
Base assembly (Table top variant only)	3020-P-5007
Refraction Stand cable Kit (R. Stand variant only)	3020-P-7014
Joystick rubber	EP39-70369
	

SUPPLIED WITH YOUR SLIT LAMP

Part name	Part number
Mains Cables – EU	2508-P-7001
Mains Cables – Brazil	3020-P-7007
Mains Cables – Japan	3020-P-7008
Mains Cables – UK	2508-P-7000
Mains Cables – USA	3020-P-7016

ADDITIONAL ACCESSORIES

Part name	Part number
Volk digital lens set	2105-L-2010
Tonometer R type	2414-P-2040
Tonometer T type	2414-P-2030

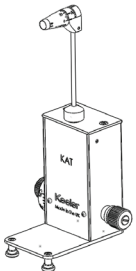
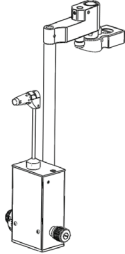

17 CONTACT, PACKAGING AND DISPOSAL INFORMATION

MANUFACTURER

Keeler Limited
Clewer Hill Road
Windsor
Berkshire
SL4 4AA

Freephone 0800 521251

Tel +44 (0) 1753 857177

Fax +44 (0) 1753 827145

USA SALES OFFICE

Keeler USA
456 Parkway
Broomall
PA 19008
USA

Toll Free 1 800 523 5620

Tel 1 610 353 4350

Fax 1 610 353 7814

INDIA OFFICE

Keeler India
Halmer India Pvt. Ltd.
B1-401, Boomerang, Chandivali
Andheri (East) Mumbai – 400072
India

Tel +91 (22) 6708 0405

Fax +91 (99303) 11090

CHINA OFFICE

Keeler China,
1012B,
KunTai International Mansion,
12B ChaoWai St.
Chao Yang District,
Beijing, 10020
China

Tel +86 (10) 51261868

Fax +86 (10) 58790155

DISPOSAL OF OLD ELECTRICAL AND ELECTRONIC EQUIPMENT

(Applicable in the European Union and other European Countries with separate Collection Systems).



This Symbol on the Product or on its Packaging and instructions indicates that it was put on the market place after August 2005 and that this product shall not be treated as Household Waste.

To Reduce the Environmental impact of WEEE (Waste Electrical Electronic Equipment) and minimise the volume of WEEE entering landfills we encourage at Product end of life that this Equipment is recycled and reused.

If you need more information on the collection reuse and recycling then please contact B2B Compliance on 01691 676124 (+44 1691 676124). (UK only).

EP59-70040

Issue 2

Keeler